

Pumps complete with motor and hydraulic power packs type RZ

Ready for installation and operation pump units with dual stage pumps acc. to D 6910

High pressure pump	Pressure $p_{\max \text{ HP}}$	= 700 bar
	Delivery flow $Q_{\max \text{ HP}}$	= 91.2 lpm (1450 rpm)
	Geo. displacement $V_{\text{geo HP}}$	= 64.2 cm ³ /rev.
Low pressure pump	Pressure $p_{\max \text{ LP}}$	= 200 bar
	Delivery flow $Q_{\max \text{ LP}}$	= 135 lpm (1450 rpm)
	Geo. displacement $V_{\text{geo LP}}$	= 89.6 cm ³ /rev.
Tank volume	V_{\max}	= 470 l

Dual stage pumps type RZ D 6910

1. General

Certain sizes of the pump combinations type RZ acc. to D 6910, sect. 2.2 are available as motor pumps or turn-key power packs, dep. on their dimensions and power requirement. The following versions are available:

- **Pump completes with motor**
for separate installation outside a tank

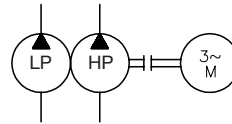

- **Hydraulic power packs for direct pipe connection**

The high pressure, low pressure and the return line are directly connected and routed to the separately mounted dual stage valve or switch units. Retrofitting of these valves (acc. to sect. 2.3) is not possible. This is important when working on the lay-out of the hydraulic system.

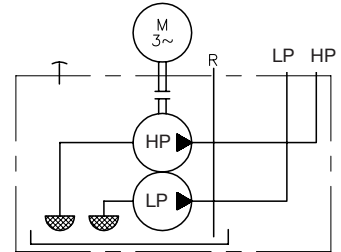

- **Hydraulic power packs with directly mounted two stage valves type NE 20 (21, 70, 80) acc. to D 7161 or switch units type CR 4 M and CR 5 M acc. to D 7150**

For parameters of the respective valves, see the specified pamphlets. It is most important to keep in mind the permissible flow rating of the selected valves, when combining them with these pumps, see selection table.

with directly mounted switch unit type CR 4M or CR 5M

with directly mounted two stage valve type NE 20 or NE 21

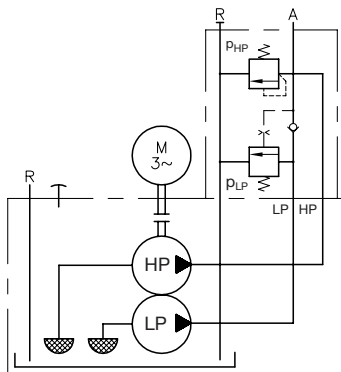

with directly mounted two stage valve type NE 70 or NE 80

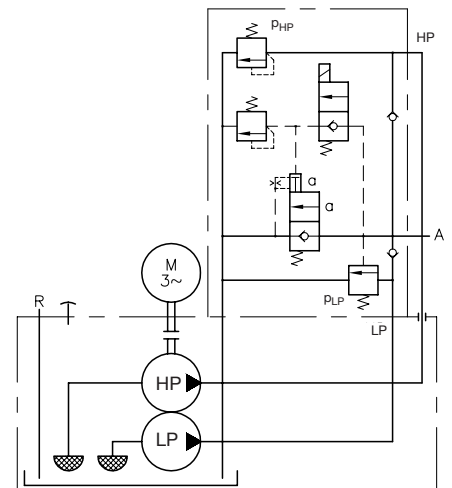
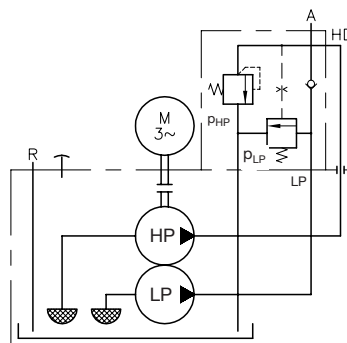

2. Available combinations

2.1 Pump completes with motor

For a listing of standard bell housings and flex-couplings, see D 6010 H sect. 6.2

Order example:

Ready for mounting at industrial standard motor

RZ 4,0/2-9/W 7,5

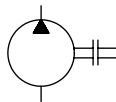

Ready for connection motor pump incl. industrial standard motor

RZ 11,8/3-87/W 7,5

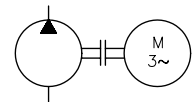

Basic pump acc. to D 6910

Motor voltage 3~ 230/400V 50Hz

Table 1: Selection table (power)

W	Ready for mounting at industrial standard motor, design IM B 35							
M	Ready for connection motor pump incl. industrial standard motor, design IM B 35							
Drive power (kW) ¹⁾	0,25 0,37	0,55 0,75	1,1 1,5	2,2 3 4	5,5 7,5 (9) ²⁾	11 15	18,5 22	30
7361	●	●	●					
6910	●	●	●	●				
6911		●	●	●	●			
6912				●	●	●		
6914					●	●	●	
6916						●	●	●

- 1) For additional data regarding radial piston pump, see D 6910
 - Power requirements, see sect. 4
 - Dimensions of drive shaft and flange, see sect. 6
- 2) A motor with this output is not standardized, but usually is like industrial standard 132 M. Drive power too high for design 6011.

Unit dimensions

All dimensions in mm, subject to change without notice!

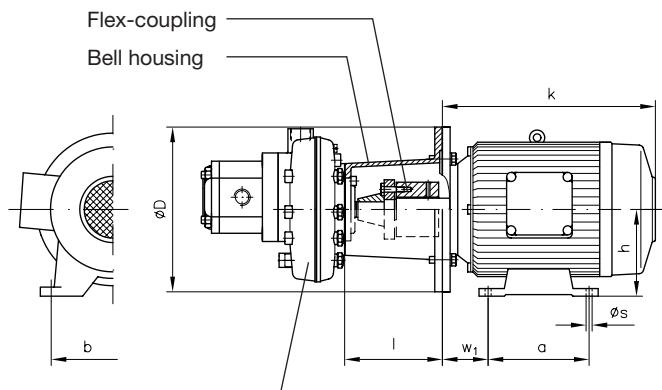

For dimensions and mass (weight) of the pump, see D 6910, sect. 6 or sect. 3

Mass (weight) approx. kg (substantial are the spec. of the manufacturer)

Power rating (kW)	Suited bell housings and flex-couplings for combination with design ³⁾						Motor ³⁾
	7631	6910	6911	6912	6914	6916	
0.25 and 0.37	3.1	3.1					6 ... 7.3
0.55 and 0.75	3.5	3.5					9 ... 10
1.1							12 ... 14
1.5	3.5	3.5	3.8				15
2.2							20 ... 21
3		3.8	3.9	4.0			23 ... 24
4		3.8	3.9	4.0			28 ... 35
5.5							45 ... 58
7.5 and 9			6.4	6.4	6.4		60 ... 80
11							80 ... 110
15				8.9	9.2	10.3	100 ... 145
18,5							115 ... 170
22					8.8	9.9	140 ... 185
30						11.9	170 ... 240

Power rating (kW)	Ext. flange-Ø D (mm)	Bell housing length l (mm), when comb. with design						Outline dimensions of industrial standard motor ⁴⁾					
		7631	6910	6911	6912	6914	6916	h	a	b	Øs	w1	k ⁴⁾
0.25 and 0.37	160	83	83					71	90	112	7	45	190 ... 210
0.55 and 0.75	200	109	109	123				80	100	125	9	50	215 ... 230
1.1	200	109	109	123				90	100	125	9 (10)	56	240 ... 250
1.5													265 ... 270
2.2	250		113	113	123			100	140	160	12	63	280 ... 320
3													
4	250		113	113	123			112	140	190	12	70	315 ... 320
5.5	300			155	155	155		132	140	178	216	12	89
7.5 and 9													330 ... 360
11	350				188	188	209	160	210	254	14	108	500 ... 520
15													500 ... 550
18,5	350				188	209	180	180	241	254	279	14 (15)	121
22													500 ... 550
30	400						212	200	305	318	18	133	620 ... 650

³⁾ Guideline data for two makes, but substantial are the spec. of the manufacturer!

⁴⁾ Not standardized! Guideline data for two makes, but substantial are the spec. of the manufacturer! See also DIN 42 673-4 and DIN 42 677-4 (outline dimensions)

2.2 Hydraulic power packs for direct pipe connection

Order example:

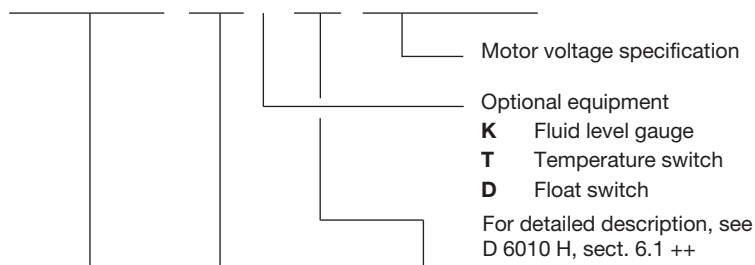
RZ 8,4/2 - 28 / B 50 K - V 4 3~ 230/400V 50 Hz**Table 2:** Possible combinations

Design of HP-stage	Dual stage pump acc. to D 6910, table sect. 2.1	Tank, see table 3 ¹⁾	Motor, see table 4	Mass (weight) approx. (kg) ²⁾	
7631	RZ 0,18 ... 1,77/1 -	2,0 ... 6,9	B 13 ... B 40	V(Z) 0,55 ... 1,5	4.1
		8,8 ... 11,3	B 20 ... B 40		4.3
6910	RZ 0,3 ... 6,5/2 -	9 ... 12,3	B 20	V(Z) 0,25 ... 3	5.4
		9 ... 28	B 30 and B 40		5.9
		9 ... 37	B 50 and B 75		6.2
6911	RZ 1,4 ... 15,3/2 -	9 ... 28	B 30 and B 40	V(Z) 0,55 ... 4	8.7
		9 ... 37	B 50 ... B 160	V(Z) 0,55 ... 5,5	9
6912	RZ 2,7 ... 30,4/2 -	9 ... 28	B 50	V(Z) 2,2 ... 7,5	12.9
		9 ... 37	B 75 ... B 160	V(Z) 2,2 ... 11	13.2
6914	RZ 6,1 ... 60,8/2 -	9 ... 37	B 100 ... B 400	V(Z) 5,5 ... 22	26.6
6911	RZ 0,9 ... 15,3/3 -	45 and 59	B 50	V(Z) 0,55 ... 7,5	11.8
			B 75 ... B 160	V(Z) 0,55 ... 11	11.8
		75 and 87	B 100 ... B 400	V(Z) 5.5 ... 11	13.6
6912	RZ 2,7 ... 30,4/3 -	45 and 59	B 160 ... B 400	V(Z) 2,2 ... 11	16
		75 and 87	B 160 ... B 400	V(Z) 5,5 ... 11	17.8
6914	RZ 6,1 ... 60,8/3 -	45 ... 87	B 160 ... B 400	V(Z) 5,5 ... 22	31.2

Table 3: Tanks for hydraulic power packs acc. to sect. 2.2 and 2.3; For dimensional drawings, see sect. 3.2 and 3.3

Coding		B 13	B 20	B 30	B 40	B 50	B 75	B 100	B 160	B 250	B 400
Tank volume approx. (l)	Filling volume	16	26.5	37	47	90	110	150	190	315	470
	Usable filling volume	12	22	32	42	60	80	100 (90) () - value for type RZ ./3-87	140 (130)	250	400
Mass (weight) approx. (kg) Tank and accessories, without fluid filling		8.5	10	12.5	14.5	30	32	52	59	102	126
Mass (weight) of the fluid filling in kg approx. 0.9 x filling volume											

Table 4: Motor design B 5 (V1) for hydraulic power packs acc. to sect. 2.2 and 2.3; For dimensional drawings, see sect. 3.1

V	Coding for utilized motor design B 5 (V1)		Nominal speed 1450 rpm (50 Hz)													
Z	Prepared for customer furnished motor ⁴⁾		Standard voltage 230/400V ΔΥ 50 Hz P _N = 0.25 ... 3 kW (265/460V 60 Hz) 400 (630)V Δ(Υ) 50 Hz P _N ≥ 4 kW (460V 60 Hz)													
P _N (kW)	0,25	0,37	0,55	0,75	1,1	1,5	2,2	3	4	5,5	7,5	9 ³⁾	11	15	18,5	22
DIN-size	71		80	90 S	90 L	100 L	112 M	132 S	132 M	160 M	160 L	180 M	180 L			

1) For cover plate versions suited for customer furnished tanks, see D 6910 Z

2) Only pump combination type RZ

3) A motor with this output is not standardized, but usually is like industrial standard 132 M. Not available from all manufacturers!

4) The selected bell housing L... acc. to D 6010, sect. 6.2 has to be specified in uncoded text, when a pump/motor combination –Z... for installation in a customer furnished tank is desired. There is a range of bell housings suited for various drive power.

2.3 Hydraulic power packs with two stage valve or built up switch unit

The hydraulic power packs listed below come with directly mounted two stage valves type NE 20 (21, 70, 80) acc. to D 7161 or switch units type CR 4 M and CR 5 M acc. to D 7150. For more detailed information about these valves, see the respective pamphlets.

Attention: Tank sizes B 13 to B 40 acc. to sect. 2.2 are **not** available with these directly mounted valves!

Order example:

RZ 6,0 /2 - 24 / B 50 - V 3 CR 4M - 280/30 3~ 230/400V 50 Hz

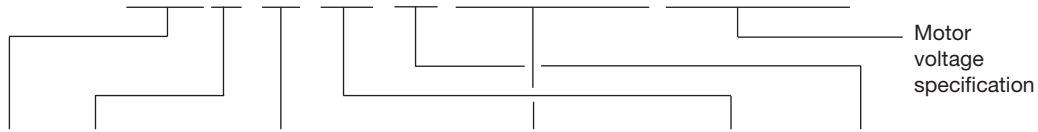

Table 5:
Possible combinations

High pressure stage HP		Size	Low pressure stage LP					Tank size (see table 3, sect. 2.2)	Motor (see table 4 sect. 2.2)		
Design	Delivery flow coding; For listing, see D 6910, sect. 2.1		Flow coding with directly mounted Two stage valve			Switch unit					
			NE 20 NE 21 ¹³⁾	NE 70	NE 80	CR 4M	CR 5M				
6910	RZ 0.3 ... 6.5 ¹⁾	/2 -	9 ... 37			21 ... 37	B 50 and B 75	V(Z) 0.25 ... 3			
6911	RZ 1.4 ... 7.0 ²⁾		9 ... 37			21 ... 37		V(Z) 0.55 ... 5.5			
	RZ 8.3 ... 11.8 ³⁾			9 ... 37		9 ... 37					
6912	RZ 2.7 ... 7.4 ⁴⁾		9 ... 37 ¹²⁾			21 ... 37		V(Z) 2.2 ... 7.5 (11)			
	RZ 8.2 and 11.6 ⁵⁾		9 ... 37		9 ... 37						
6911	RZ 0.9 ... 6.5 ¹⁾	/3 -		45 and 59		45 and 59		B 100 and B 160	V(Z) 0.25 ... 3		
	RZ 1.4 ... 11.8 ⁶⁾			45 and 59		45 and 59			V(Z) 0.55 ... 7.5 (11)		
6912	RZ 2.7 ... 11.6 ⁷⁾			45 and 59		45 and 59					
6911	RZ 1.4 ... 7.0 ²⁾	/2 -	9 ... 37			9 ... 37			B 100 and B 160	V(Z) 0.55 ... 5.5	
	RZ 8.3 ... 11.8 ³⁾			9 ... 37		9 ... 37					
	RZ 13.3 and 15.3				9 ... 37		9 ... 37				
6912	RZ 2.7 ... 7.4 ⁴⁾		9 ... 37			21 ... 37	V(Z) 2.2 ... 11				
	RZ 8.2 and 11.6 ⁵⁾			9 ... 37	9 ... 37	9 ... 37		9 ... 37			
	RZ 12.0 ... 30.4 ⁸⁾				9 ... 37			9 ... 37			
6914	RZ 6.1... 11.0 ⁹⁾		9 ... 37		9 ... 37	B 100 and B 160		V(Z) 5.5 ... 11			
	RZ 15.0 ... 25.0 ¹⁰⁾			9 ... 37						9 ... 37	
6911	RZ 0.9 ... 11.8 ¹¹⁾	/3 -		45 and 59				45 and 59		B 100 and B 160	V(Z) 0.55 ... 11
	RZ 13.3 and 15.3				45 and 59			45 and 59			
6912	RZ 2.7 ... 11.6 ⁷⁾				45 and 59			45 and 59			V(Z) 2.2 ... 11
	RZ 12.0 ... 30.4 ⁸⁾				45 and 59			45 and 59			
6914	RZ 6.1... 11.0 ⁹⁾				45 and 59			45 and 59	V(Z) 0.55 ... 22		
	RZ 15.0 ... 25.0 ¹⁰⁾				45 and 59			45 and 59			
6911	RZ 0.9 ... 11.8 ¹¹⁾				75 and 87			75 and 87	B 100 and B 160		V(Z) 0.55 ... 11
	RZ 13.3 and 15.3				75 and 87			75 and 87			
6912	RZ 2.7 ... 11.6 ⁷⁾				75 and 87			75 and 87			V(Z) 2.2 ... 11
	RZ 12.0 ... 30.4 ⁸⁾				75 and 87			75 and 87			
6914	RZ 6.1... 11.0 ⁹⁾				75 and 87		75 and 87	V(Z) 5.5 ... 22			
	RZ 15.0 ... 25.0 ¹⁰⁾				75 and 87		75 and 87				
6911	RZ 0.9 ... 11.8 ¹¹⁾	/3 -		75 and 87		75 and 87	B 250 and B 400	V(Z) 5.5 ... 11			
	RZ 13.3 and 15.3				75 and 87				75 and 87		
6912	RZ 2.7 ... 11.6 ⁷⁾				75 and 87				75 and 87		
	RZ 12.0 ... 30.4 ⁸⁾				75 and 87				75 and 87		

1) 0.3 - 0.41 - 0.5 - 0.8 - 1.2 - 1.45 - 1.7 - 1.9 - 2.2
0.6 - 0.83 - 1.0 - 1.6 - 2.4 - 2.8 - 3.3 - 3.8 - 4.4
0.9 - 1.25 - 1.5 - 2.5 - 3.6 - 4.3 - 5.1 - 5.6 - 6.5

2) 1.4 - 2.08 - 2.6 - 4.2 - 6.0 - 7.0
2.1 - 2.9 - 3.7 - 5.8

3) 8.3 - 9.6 - 10.9
8.4 - 9.8 - 11.8

4) 2.7 - 4.15 - 5.3
4.0 - 5.85 - 7.4

5) 8.2 - 11.6

6) 1.4 - 2.08 - 2.6 - 4.2 - 6.0 - 7.0 - 8.3 - 9.6 - 10.9
2.1 - 2.9 - 3.7 - 5.8 - 8.4 - 9.8 - 11.8

7) 2.7 - 4.15 - 5.3 - 8.2
4.0 - 5.85 - 7.4 - 11.6

8) 12.0 - 14.2 - 16.8 - 19.3 - 21.7
17.0 - 20.0 - 23.5 - 26.5 - 30.4

9) 6.1 - 5.35 - 11.0
8.0 - 11.65

10) 17.4 - 25.0
15.0 - 23.0

11) 0.9 - 1.25 - 1.5 - 2.5 - 3.6 - 4.3 - 5.1 - 5.6 - 6.5
1.4 - 2.08 - 2.6 - 4.2 - 6.0 - 7.0 - 8.3 - 9.6 - 10.9
2.1 - 2.9 - 3.7 - 5.8 - 8.4 - 9.8 - 11.8 - 13.3 - 15.3

12) Pump combination RZ 2.7 ... 7.4/2-16 ... 37 /B 50 together with NE 20 or NE 21 only available with drive power up to 4 kW (V/Z 4)

13) Directional seated valve banks type VB 11(21)G... acc. to D 7302 can be directly mounted at the two stage valve type NE 21

3. Unit dimensions

All dimensions in mm, subject to change without notice!

3.1 Motors

P _N (kW)	DIN-size	Main dimensions (mm) acc. to DIN 42 948				Mass (weight) approx. (kg) ³⁾
		D	d	L	approx. H ¹⁾	
0.25	71	160	14	30	210	5.5 + 1
0.37						6.8 + 2
0.55	80	200	19	40	230	8 + 2
0.75						10 + 2
1.1	90 S	200	24	50	250	12 + 2
1.5	90 L					14 + 2
2.2	100 L	250	28	60	320	18 + 2
3						22 + 3
4	112 M	300	38	80	360	28 + 3
5.5	132 S					56 + 4
7.5	132 M	350	42	100	460	68 + 5
9 ¹⁾ ²⁾	2)					70 + 5
11	160 M	350	48	110	550	100 + 5
15	160 L					125 + 6
18.5	180 M	350	48	110	580	154 + 6
22	180 L					170 + 6

Motor design B 5 (V1)

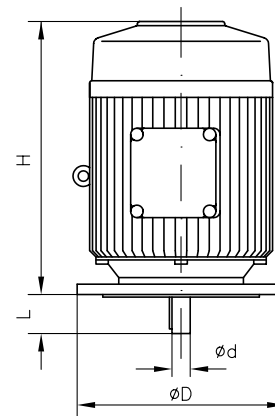

This dimension is not standardized and depends on the make.

- 1) Not standardized
- 2) A motor with this output is not standardized, but usually is like industrial standard 132 M
- 3) Motor + flex-coupling; only reference value, as the motor mass (weight) depends on the make; rounded coupling weight

3.2 Tanks for hydraulic power packs type RZ acc. to sect. 2.2

Tank size B 13 to B 40

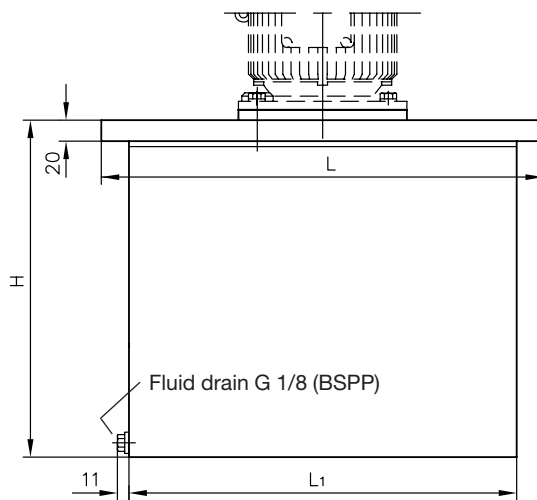

For detailed tank dimensions, see D 6010 H!

Tank size	B	B ₁	H	L	L ₁	b
B 13	260	---	244	450	370	180
B 20	260	---	334	450	370	180
B 30	320	---	334	510	450	210
B 40	320	440	334	510	450	210

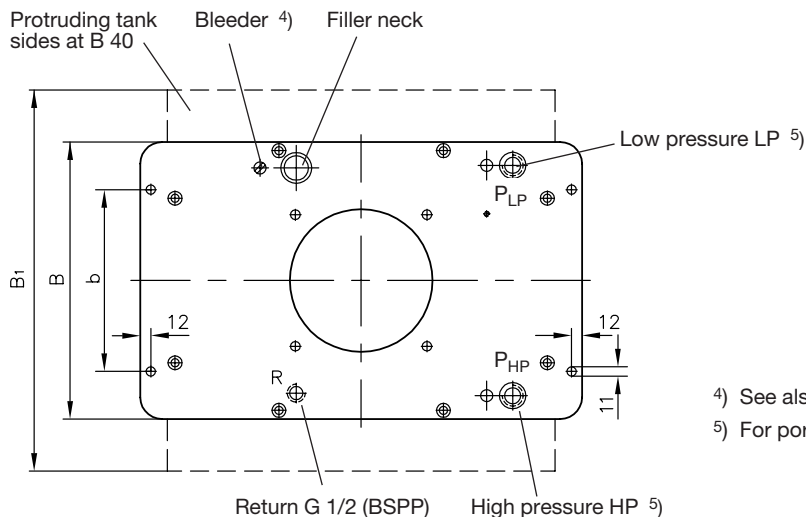

- 4) See also notes in sect. 4
- 5) For port size, see table 6, page 6

Tank size B 50 to B 400

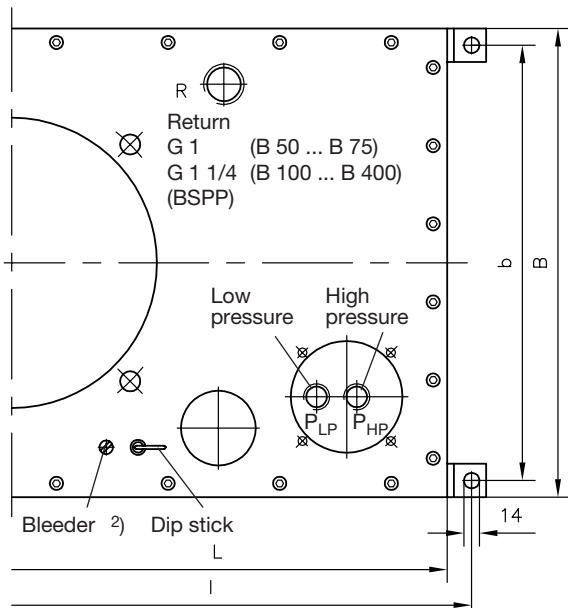
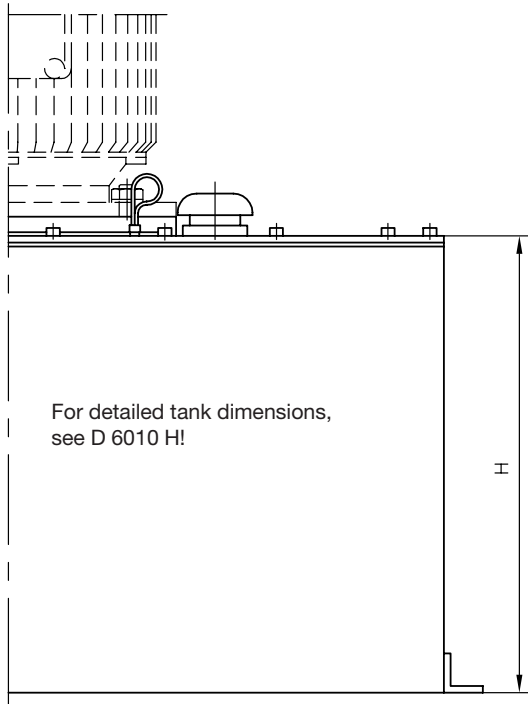

Tank size	H	B	b	L	I
B 50	405	420	390	600	630
B 75	480	420	390	600	630
B 100	536	500	470	650	680
B 160	666	500	470	650	680
B 250	575	650	620	1000	1044
B 400	825	650	620	1000	1044

Table 6:

Port size (ISO 228/1) (BSPP) of both pressure ports P_{HP} ¹⁾ and P_{LP}

Pump combination acc. to sect. 2.2		Tank size			
		B 13 B 20	B 30	B 40	B 50 B 75
RZ 0.3/2- to RZ 6.5/2-	9 ... 12.3 9 ... 28 37	G 1/2 --- ---	G 1/2 G 1/2 ---	G 1/2 G 1/2 G 3/4	

Pump combination acc. to sect. 2.2		Tank size				
		B 30 B 40	B 50	B 75	B 100 B 160	B 250 B 400
RZ 1.4/2- to RZ 15.3/2-	9 ... 28 37	G 1/2 ---	G 1/2 G 3/4	---		
RZ 2.7/2- to RZ 30.4/2-	9 ... 28 37	---	G 1/2 ---	G 3/4	G 3/4	
RZ 6.1/2- to RZ 60.8/2-	9 ... 37	---	---	G 3/4		

Pump combination acc. to sect. 2.2		Tank size			
		B 50	B 75	B 100 B 160	B 250 B 400
RZ 0.9/3 - 45 and 59 to RZ 15.3/3 - 45 and 59		G 3/4		G 3/4	
RZ 2.7/3 - 45 and 59 to RZ 30.4/3 - 45 and 59		---	G 3/4	G 3/4	

Pump combination acc. to sect. 2.2		Tank size			
		B 100	B 160	B 250	B 400
RZ 6.1/3 - 45 and 59 to RZ 60.8/3 - 45 and 59		---	G 3/4	G 3/4	
RZ 0.9/3 - 75 and 87 to RZ 60.8/3 - 75 and 87		G 1		G 1	
RZ 0.9/3 - 110 and 135 to RZ 30.4/3 - 110 and 135		G 1		G 1	

1) The port size of P_{HP} and P_{LP} are identical due to design reasons. It may be advantageous to reduce them via fittings (reducer) acc. to D 845.

2) See also notes in sect. 4

3.3 Tanks for hydraulic power packs type RZ acc. to sect. 2.3

Tank B 50 to B 400 with directly mounted two stage valve/switch unit.

For tank dimensions, see sect. 3.2. For dimensions of directly mounted two stage valves type NE 20(21, 70, 80) see D 7161 for switch units type CR 4 M and CR 5 M see D 7150.

Type B 50 ... B 160 with NE 20 (NE 21)

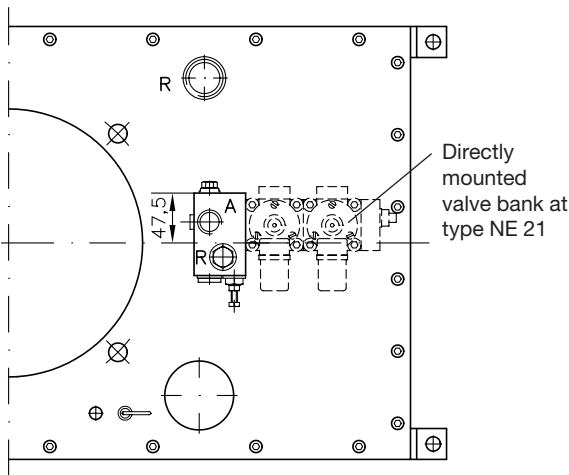
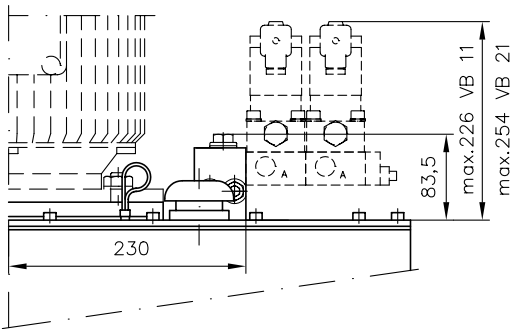

Type B 50 ... B 400 with NE 70 (NE 80)

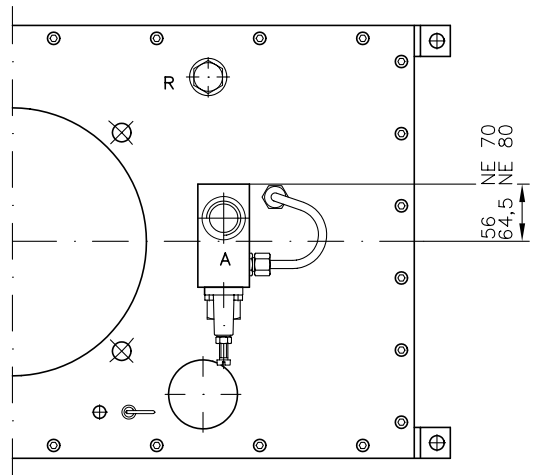
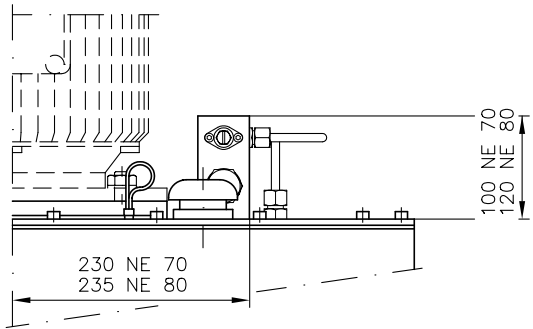

Type B 50 ... B 400 with CR 4M (CR 5M)

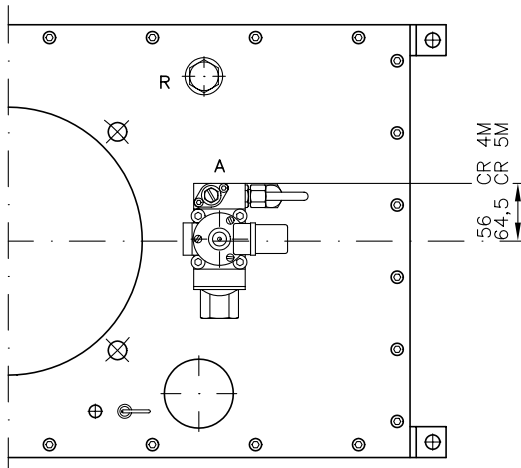
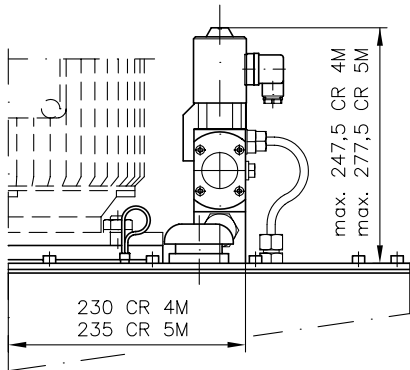

4. Notes regarding installation

4.1 Accessory acc. to D 6910 Z

When installing a pump type RZ in a customer furnished tank usually also the lines from both pumps (HP and LP) to the cover plate have to be customer furnished.

Required components:	Motor	see sect. 2.1 and 2.2
	Cover plate	see D 6910 Z
	Flex-coupling / bell-housing	see D 6010 H, sect. 6.2
	Suction line	see D 6910 Z

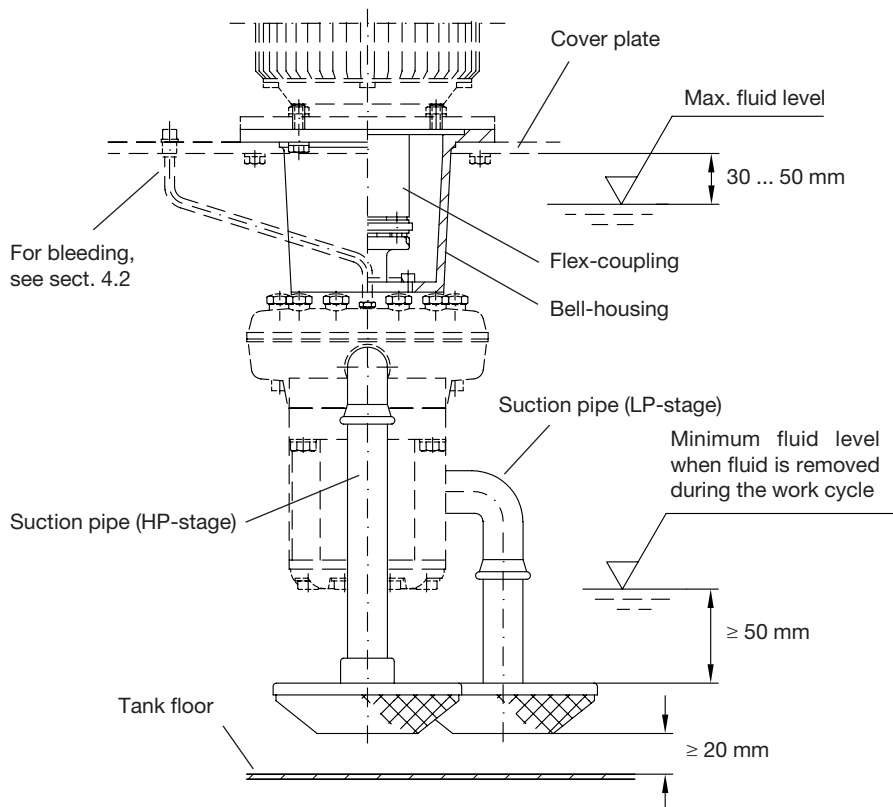

4.2 Initial operation, bleeding

Hydraulic power packs acc. to sect. 2.2 and 2.3.

Remove the bleeder screw (see dimensional drawings) prior to filling the tank, fill in the fluid, wait for 5 minutes and reinstall/tighten the bleeder screw. The tank should be well-filled during start-up but not absolutely full so as to allow the fluid to expand while reaching operation temperature. Then allow pump (HP- and LP-pressure stage) to run briefly without pressure (assuming the control system provides this possibility). Otherwise set back the pressure limiting valve to zero pressure and run the pump without pressure. Then run the hydraulic system through several cycles without load (possibly with the pressure-limiting valve set back), until all functions take place freely and smoothly in the time calculated. Finally, return the pressure-limiting valve to the setting for operation (always checked by a pressure gauge). The coupling must not get in contact with the pressure fluid.